



VACUUM PACKING MACHINE SU-310P 230/50-60/1

Tabletop model. 10 m³/h. 320 mm.



P/N 1140732



INCLUDES

- ✓ Filling plate
- ✓ Bluetooth connectivity
- ✓ Printer connection

ACCESSORIES

- Filling plates
- Liquid insert plates
- Vac-norm external vacuum kits
- Vac-norm containers
- Smooth bags for vacuum packing
- Trolley for vacuum packing
- machines
- Thermal labels for CG2 / RB printer
- RB Desktop printer for SU vacuum packing machines
- Thermal transfer labels for RB printer

SALES DESCRIPTION

320 mm. sealing bar.
 10 m³/h Busch vacuum pump.
 Vacuum controlled by sensor.

- ✓ Powered by Busch.
- ✓ Vacuum controlled by sensor.
- ✓ Vacuum PLUS.
- ✓ LCD colour screen: all information at a glance.
- ✓ Backlit touch keyboard.
- ✓ Programmable: 25-programme memory. Blocking option.
- ✓ "Pause" button.
- ✓ Phased vacuum programme.
- ✓ Detection of the evaporation of liquids.
- ✓ Double seal.
- ✓ Cordless sealing bar.
- ✓ Progressive decompression.
- ✓ Vac-Norm ready with Automatic decompression.
- ✓ Stainless steel body and chamber. Deep-drawn chamber.
- ✓ Damped transparent lid of high durability polycarbonate.
- ✓ Dry-oil programme for drying the pump.
- ✓ Working hours counter for oil changes.
- ✓ Safety system with protection against vacuum failure.
- ✓ NSF-listed model.



sammic | www.sammic.com
Food Service Equipment Manufacturer

Polígono Basarte, 1.
 20720 Azkoitia, Spain

phone +34 943 15 72 36
sales@sammic.com



| | |
|----------|------|
| Project | Date |
| Item | Qty |
| Approved | |

FOOD PRESERVATION AND SOUS-VIDE
 VACUUM PACKING MACHINES - "SENSOR ULTRA" LINE

product sheet
 updated 30/11/2021



VACUUM PACKING MACHINE SU-310P 230/50-60/1

Tabletop model. 10 m³/h. 320 mm.



P/N 1140732

SPECIFICATIONS

Pump capacity: 10 m³/h
 Bar length: 320 mm
 Total loading: 370 W
 Vacuum pressure (maximum): 2 mbar
 Electrical supply: 230 V / 50-60 Hz / 1 ~
 (3.4 A)
 Plug: EU (SCHUKO 2P+G)

Internal dimensions

- ✓ Width: 330 mm
- ✓ Depth: 360 mm
- ✓ Height: 155 mm

External dimensions (WxDxH)

- ✓ Width: 384 mm
- ✓ Depth: 465 mm
- ✓ Height: 403 mm

Net weight: 39.5 Kg
 Noise level (1m.): 75 dB(A)
 Background noise: 32 dB(A)

Crated dimensions

460 x 530 x 460 mm
 Gross weight: 43 Kg.

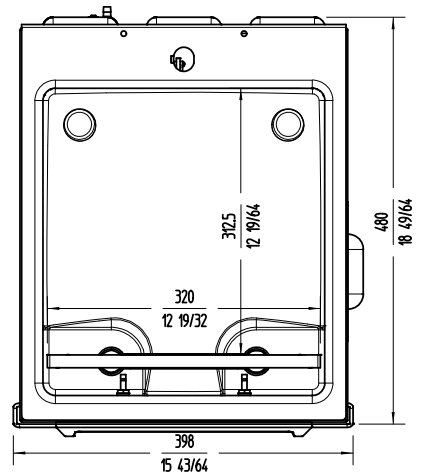
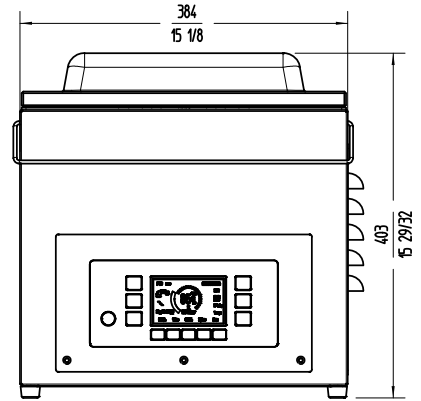
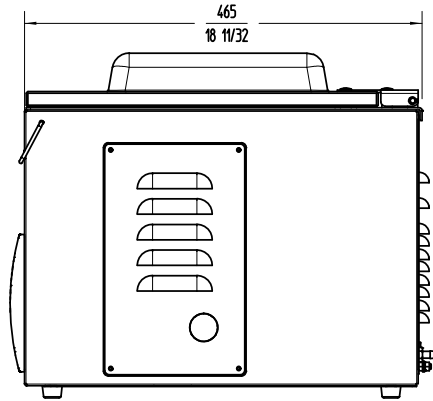

FOOD PRESERVATION AND SOUS-VIDE
 VACUUM PACKING MACHINES - "SENSOR ULTRA" LINE

 **sammic** | www.sammic.com
Food Service Equipment Manufacturer

Polígono Basarte, 1. phone +34 943 15 72 36
 20720 Azkoitia, Spain sales@sammic.com



| | |
|----------|------|
| Project | Date |
| Item | Qty |
| Approved | |

product sheet
 updated 30/11/2021