



---

---

**RANGE**  
**(ELECTRICAL)**

---

---

**INSTRUCTION AND**  
**MAINTENANCE MANUAL**

## DESCRIPTION

Our dear customer,

Your preferred COMBISTEEL is nature and technology friendly. We thank you for your choice.

COMBISTEEL has been produced with the understanding of "Total Quality" in modern production facilities.

### Important Safety Information

**Carefully read this guide and keep it for future review.**

**WARNING:** Installation of the devices must be done by an authorized service person.

**WARNING:** Equipment must be grounded.



Indicates that there is a risk of personal injury or property damage.



Explosion / fire hazard.

- The instructions in this manual contain important information on the safe mounting, usage, cleaning and maintenance of the device. Thus, keep the manual at a place easily accessible by the person who will use the machine, and the technician.
- Mounting, electrical connection and maintenance works of the device should be performed by a specialist authorized in this subject and in accordance with the instructions of the manufacturer company.
- Electrical connection of the device should be arranged according to the tables and electrical diagram given in this manual.
- Manufacturer Company accepts no responsibility for the final damages incurred in humans or properties that are caused by any procedure not conforming to the instruction manual, or maintenance or technical interventions that are not performed by authorized people.

### Product Types

- 7178.0015 – 600 serie ½ module counter top
- 7178.0020 – 600 serie 1 module counter top
- 7178.0430 – 700 serie ½ module cupboard
- 7178.0435 – 700 serie 1 module cupboard
- 7178.0430 – 700 serie 1 module oven

**Please check the table (1) below for the product specifications**

## MOUNTING

### Placement

- Installation and adjustment of the device should be carried out by technical staff of the Authorized Service.
- Place the device at a place min. 10cm away from the side or back wall to prevent excessive temperature rises.
- Place the device beneath a filtered exhaust hood in order to eliminate smell and fume that may be emitted during cooking.
- Device should be placed on a flat surface by suitably balancing on the four adjustable legs. (Figure A)
- Remove the protective nylon on the device. Clean the adhesive particles left on the device with a suitable cleaner.
- Never leave flammable material near the device.

### Electrical Connection

- Connect the device to the electrical installation according to the electrical standards of the relevant country.
- Feed the device with suitable network voltage written on the information plate.
- Connect to the electrical installation over a suitable automatic fuse. Fix the said fuse on a place that is easily accessible in case of a danger.
- The cable connecting the device to the electrical installation should be at least type H05 RNF.
- Before connecting the electrical inlet cable to the inlet clamp on the device, connect the cable by passing it through the inlet coupling. And then tighten the coupling cover in a manner that does not allow cable return.
- Electrical inlet is indicated with a label on the device.
- If the device will be used in a commercial kitchen, apply a correct grounding system. Here, consider DIN VDE D100 Article 540.
- Grounding screw ”  ” is indicated with a label behind the device.

## OPERATOR INSTRUCTIONS

- With the aim of eliminating the protection oil on it, operate the device and ovens at maximum level for a while. Then, cover with vegetable oil again.
- Clean the accumulated food residues that are burned and carbonized on the cooking surface and oven with a suitable tool everyday at the end of operation. If the said daily maintenance is not performed, accumulated burned food residues may cause a decline in cooking efficiency by creating a crust on the plates
- Do not operate the oven with its back funnel mouldings removed or closed.

## BEFORE USE

### Electrical system check

- After mounting, check the controlling members and heaters by operating at different temperatures.
- After the installation and maintenance, check the heating power of device.
- During first operation, device will emit fume and smell for a short period. This fume and smell is the result of the insulation material and the substances such as oil, etc. on the metal sheet surfaces. This is not dangerous and will disappear by itself.
- During the first use of the device should be run in the highest degree of operating for a period of 1 hour

## STARTING-UP COOKERS (Figure B)

- Each plate has 6 adjustable Temperature value. Desired Temperature level is set with relevant button (1).
- 1 is the lowest Temperature and 6 is the highest Temperature.

## STARTING-UP OVEN (Figure B)

- Adjust the thermostat to desired temperature (2).
- Adjust cooking area (4), you will see that the indicator light is on.
- When the indicator (3) light is off, it means that the oven has reached the desired temperature.
- Positions of change over switch is below:



TURN OFF



(Up 1500W down 4500W)



Upper Heater (Up 4500W)



Lower Heater (Down 4500W)

## TURN OFF

- Turn the switch to position “0”.
- Turn the thermostat to position “0”.

## MAINTENANCE

- Do not perform maintenance when the device is loaded with electrical power.
- Before it cools down completely, wipe the device with a cloth immersed in warm soapy water.
- Do not use cleaning substances and tools that may cause scratches on device surface.
- Do not clean the device with water or vapour pressure. Otherwise, you may cause electrical plate failure.
- If the device will not be used for a long period, coat the surfaces with a thin layer of Vaseline. In case of any dangerous condition with the device, notify to the authorized service. Never let unauthorized people to interfere in the device.

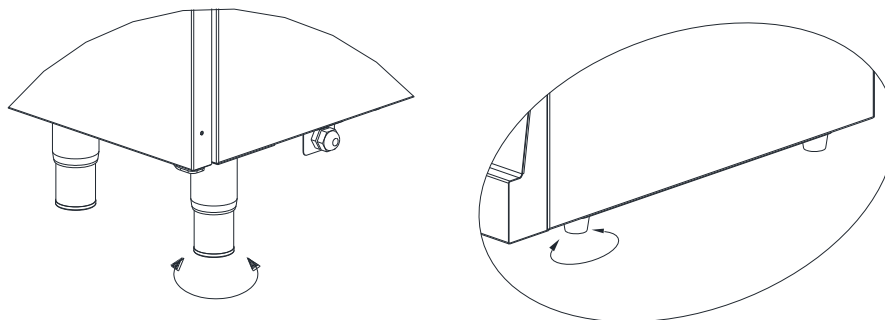



Figure A

## Compatibility Information

This device is designed and manufactured in accordance with the following directives and standards.

 marking directive, 93/68/EEC  
TS EN 60335-1:2012/AC  
TS EN 60335-2:37

Related to CE Directive(s):  
2014/35/EU (Low Voltage)

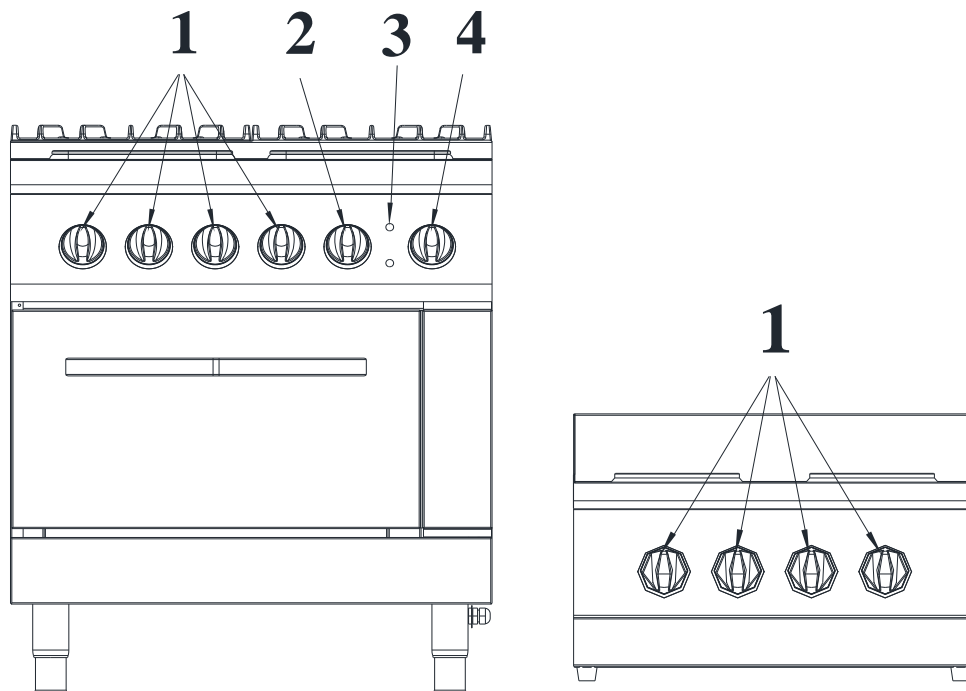
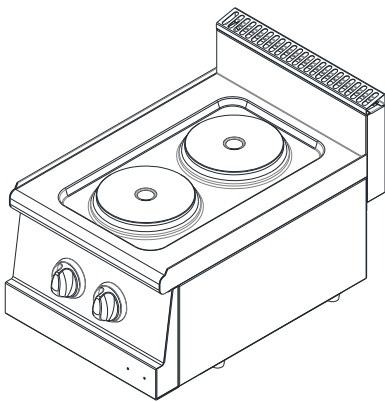

**Figure B**

- **Limitation of Liability:** All technical information contained in this manual, operating instructions, operation and maintenance of the device, contains the latest information on your device. The manufacturer accepts no responsibility for damage or injury which may result from failure to follow the instructions in this manual, use outside of the intended use, unauthorized repair, unauthorized modifications to the device, or use of spare parts not approved by the manufacturer.

		<b>7178.0015</b>	<b>7178.0020</b>	<b>7178.0425</b>	<b>7178.0430</b>	<b>7178.0435</b>
<b>Width (A)</b>	mm	400	600	400	800	800
<b>Dept (B)</b>	mm	600	600	730	730	730
<b>Hight (C)</b>	mm	300	300	900	900	900
<b>Power</b>	<b>Kw</b>	<b>3 Kw</b>	<b>6 Kw</b>	<b>4 Kw</b>	<b>8 Kw</b>	<b>17 Kw</b>
<b>Electrical Inlet</b>		400 V 3N PE	400 V 3N PE	400 V 3N PE	400 V 3N PE	400 V 3N PE
<b>Cable Sections</b>	mm <sup>2</sup>	5x2,5	5x2,5	5x2,5	5x4	5x4

**Table (1)**



**7178.0015**

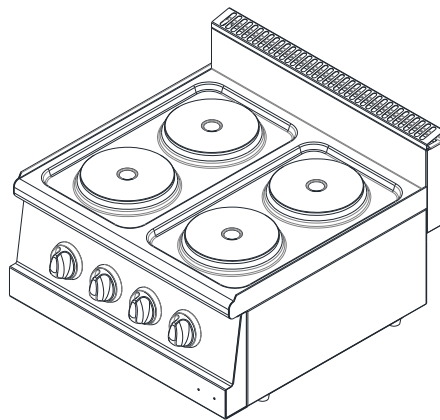

**7178.0020**

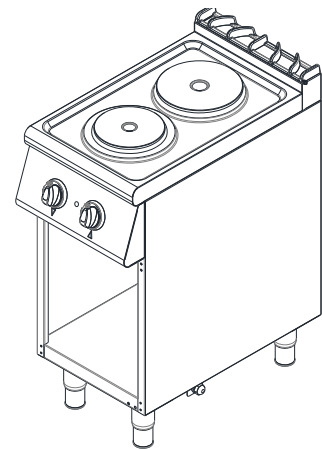

**7178.0425**

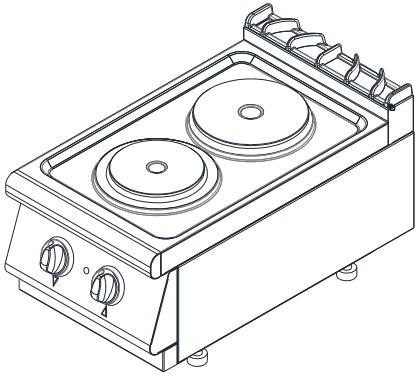

**7178.0215**

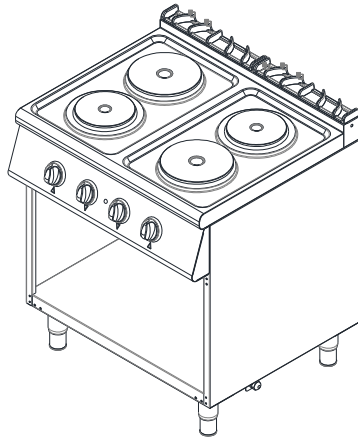

**7178.0430**

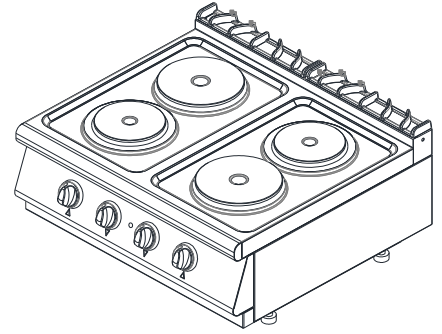

**7178.0220**

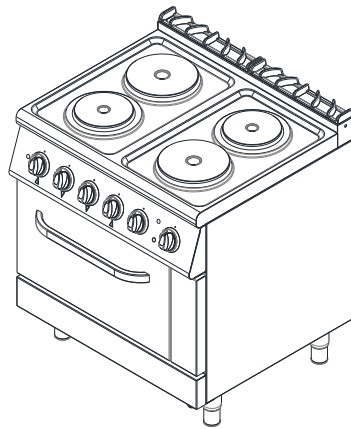

**7178.0435**

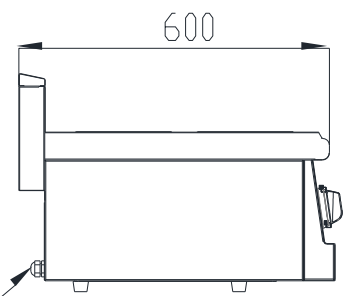
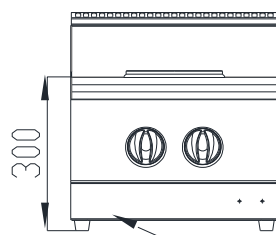
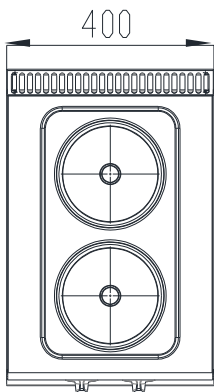

ELECTRICAL INLET

**7178.0015**

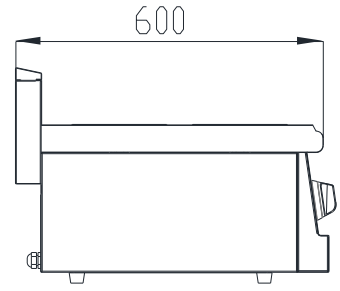
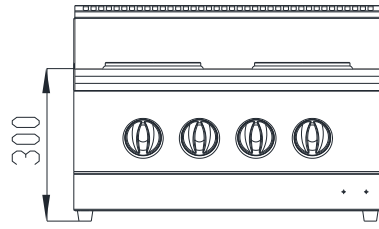
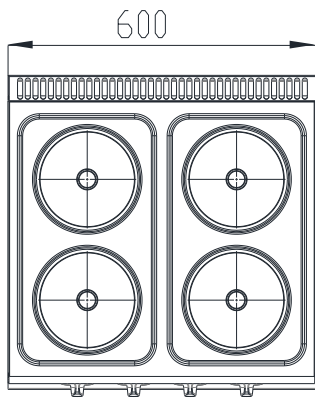

**7178.0020**

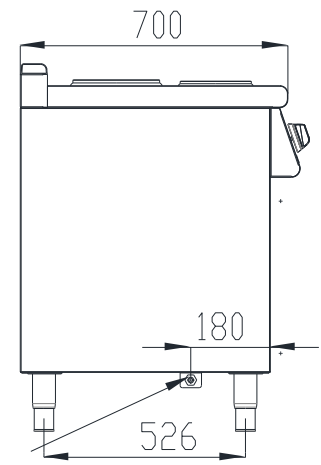
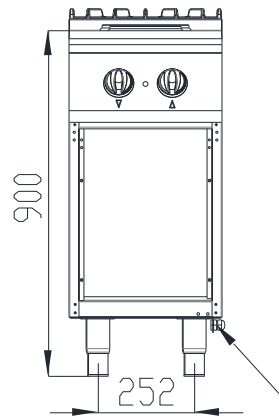
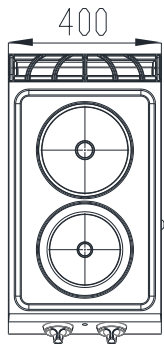

**7178.0425**

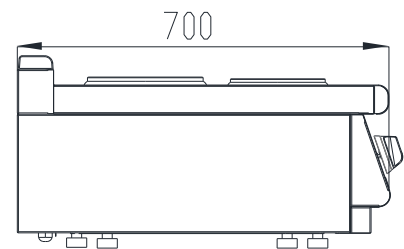
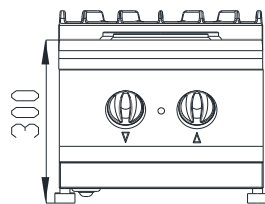
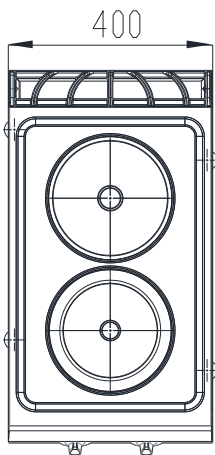

**7178.0215**



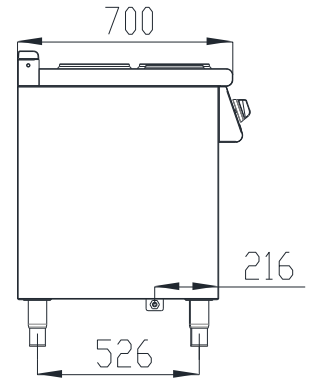
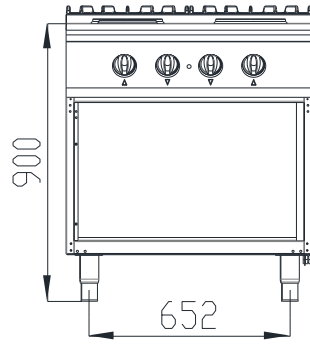
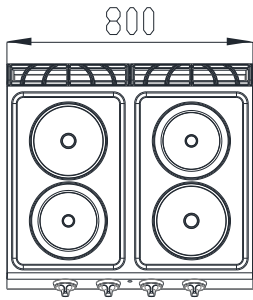

**7178.0430**

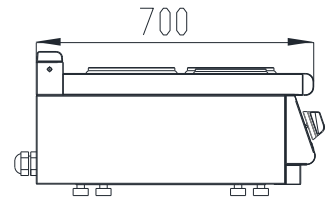
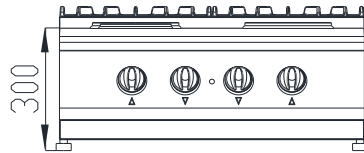
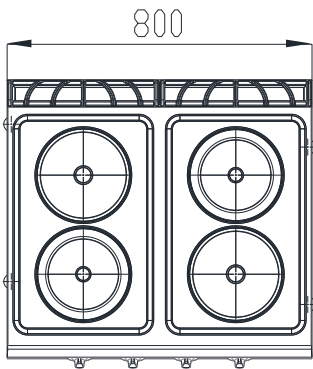

**7178.0220**

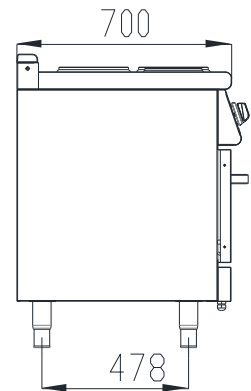
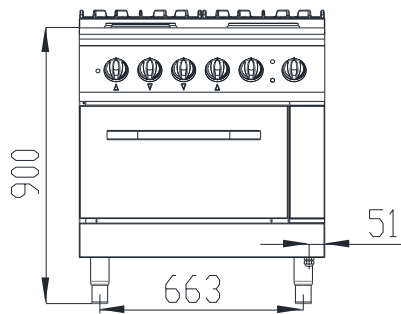
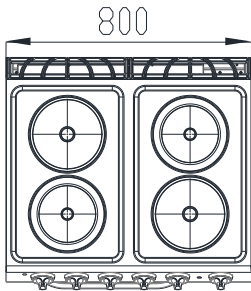

**7178.0435**

# 400V AC 3N PE

5X2.5mm<sup>2</sup> H07 RNF

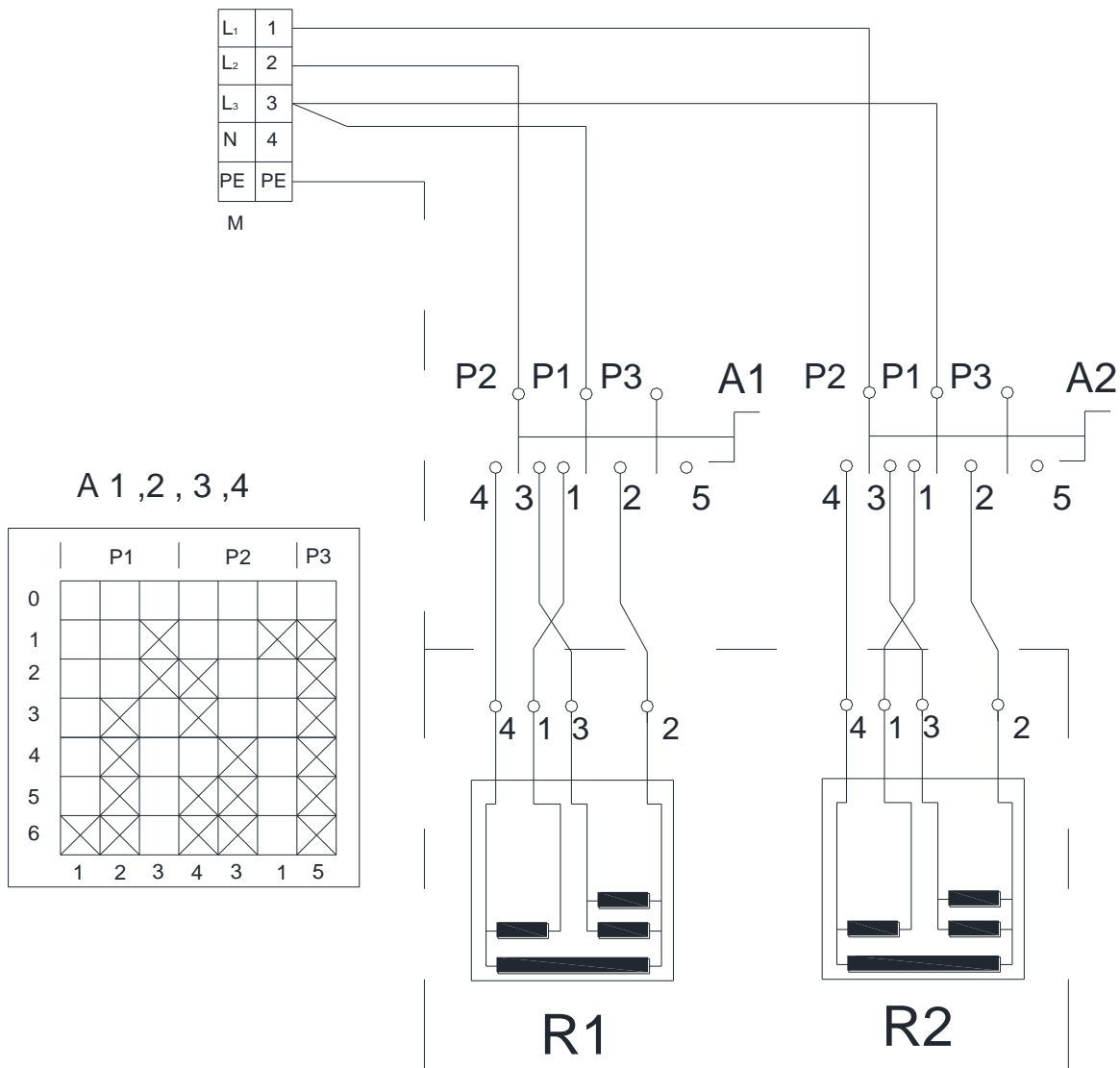

M - INLET CLAMP

R1,2 - PLATES

A1,2 - PLATE SWITCHES

# 400V AC 3N PE

5X2.5mm<sup>2</sup> H07 RNF

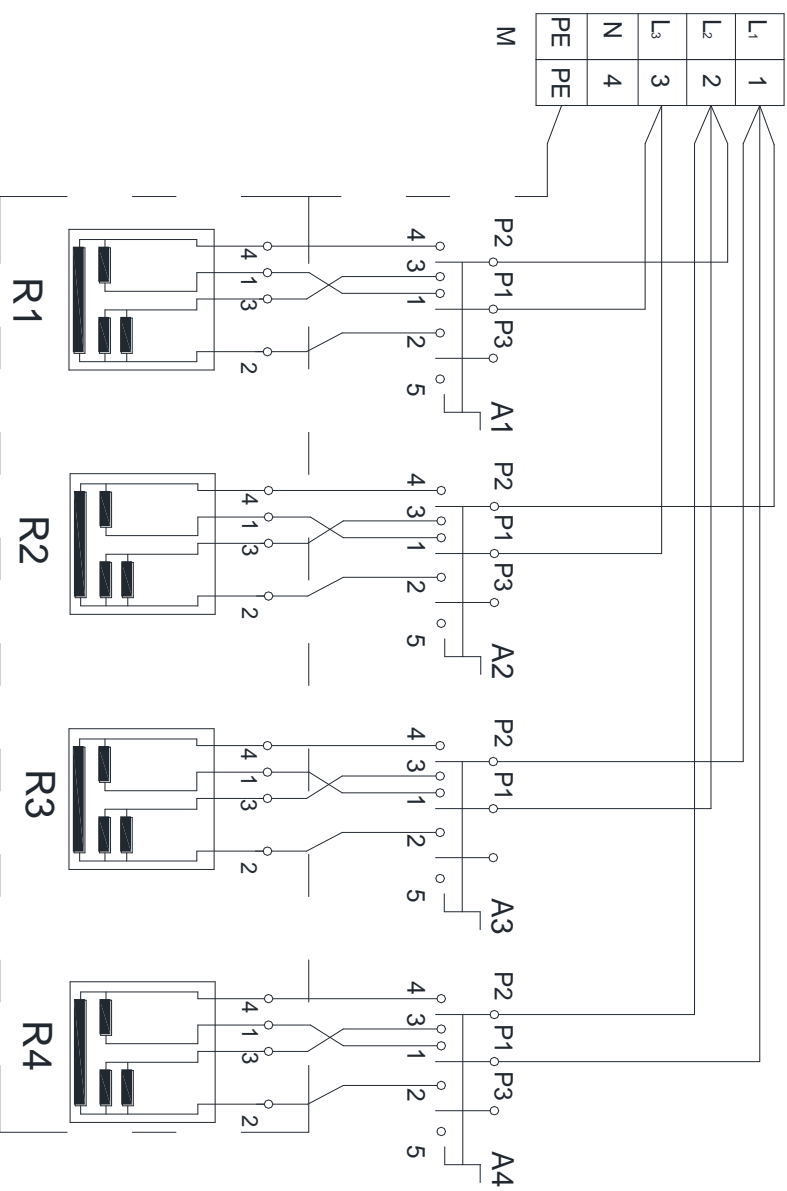

- M - INLET CLAMP
- R1,2,3,4 - PLATES
- A1,2,3,4 - PLATE SWITCHES

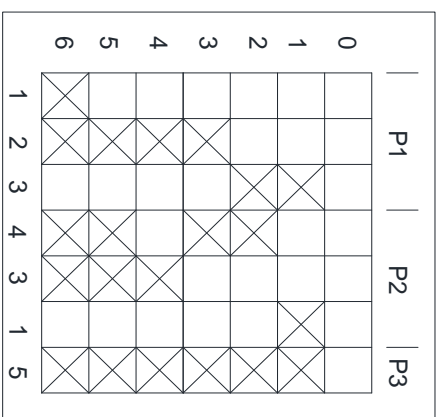

# 400V AC 3N PE

5X4mm<sup>2</sup> H07 RNF

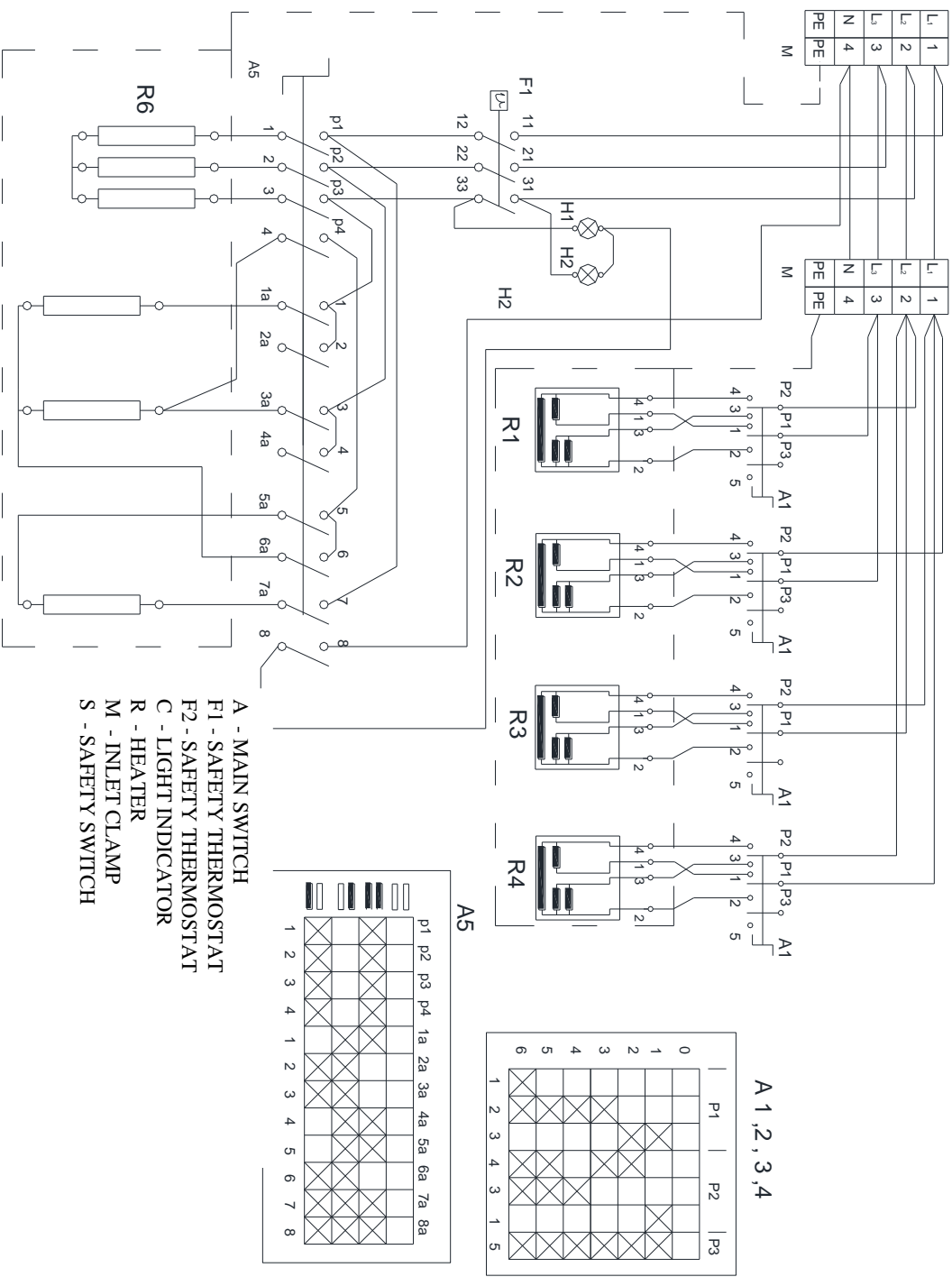

# 400V AC 3N PE

5X4mm<sup>2</sup> H07 RNF

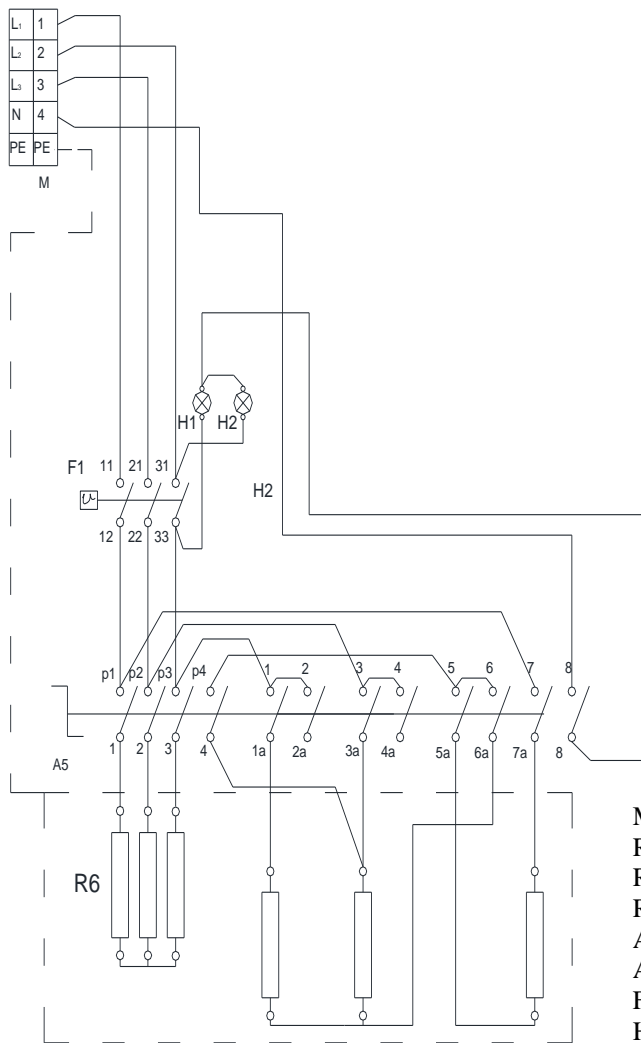

A5

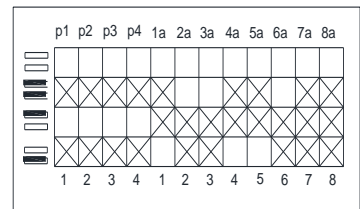

- M - INLET CLAMP
- R1,2,3,4 - PLATES
- R5 - OVEN TOP HEATERS
- R6 - OVEN BOTTOM HEATERS
- A1,2,3,4 - PLATE SWITCHES
- A5 - OVEN SWITCH
- F1 - THERMOSTAT
- H1,2 - LIGHT INDICATOR

## 600 Series Device Fixing Scheme

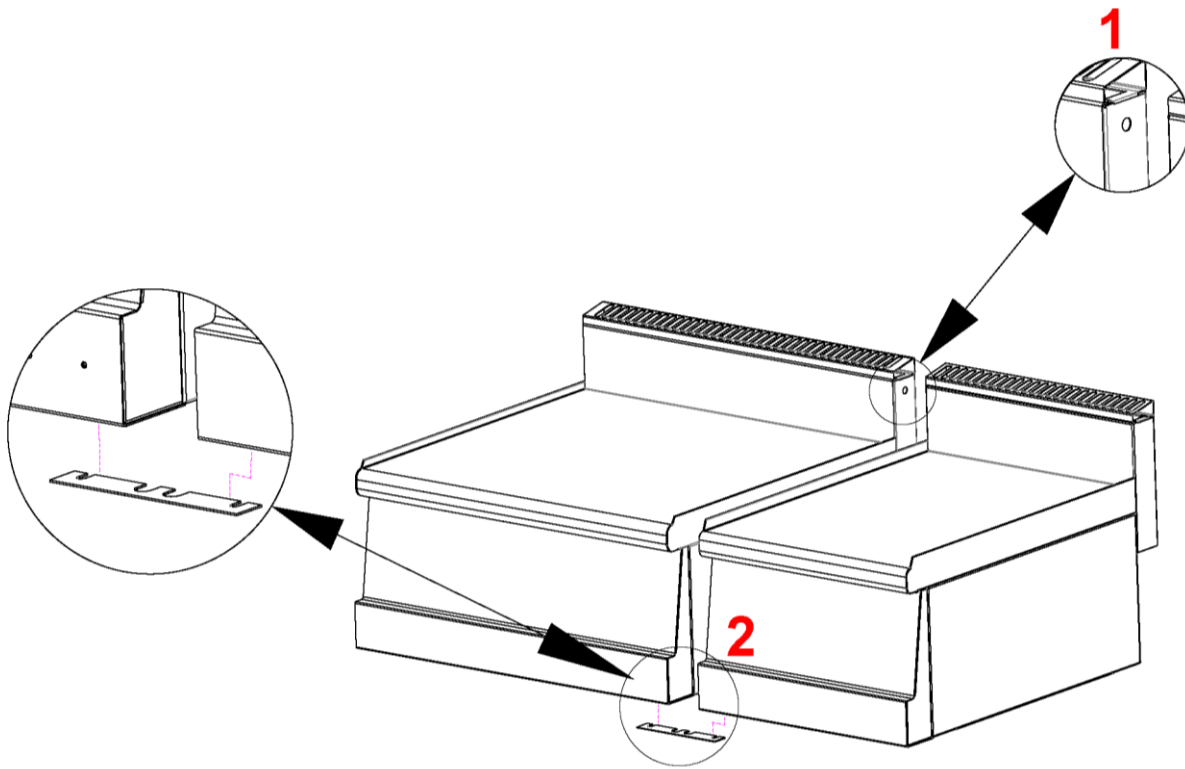

## 700 Series Device Fixing Scheme

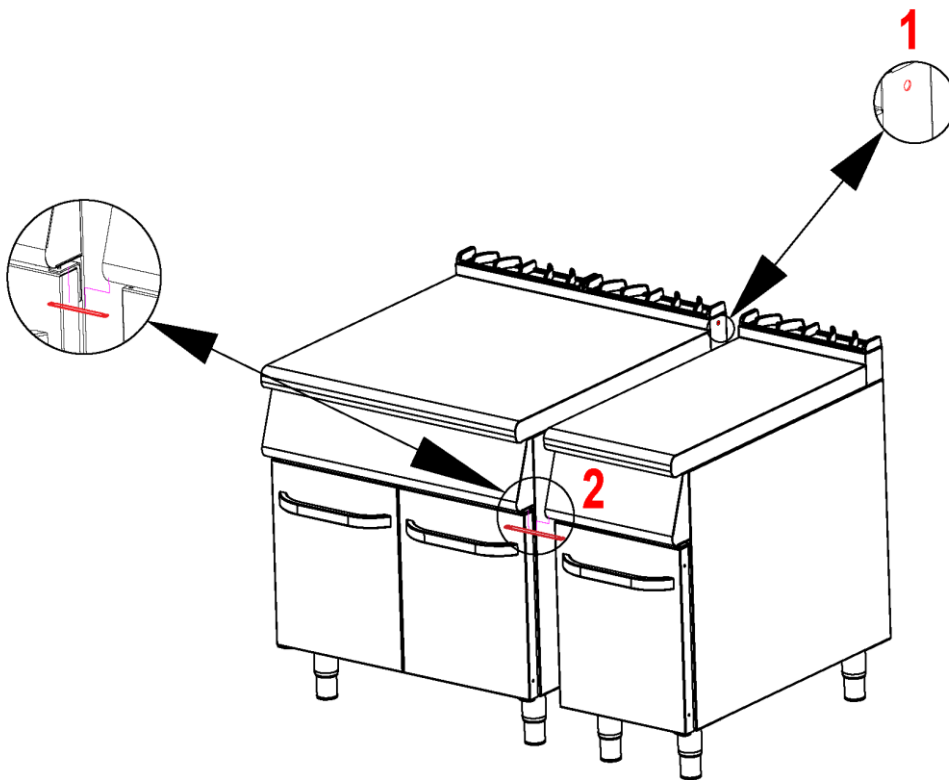



# CORRECTIVE \ PREVENTIVE ACTIVE FORM

## DETECTION TYPE

OPTIMIZATION REQUEST/ DESCRIPTION	CUSTOMER NAME	CUSTOMER COMPLAINT
PRODUCT NAME:	DETECTED ( Name , Appellation)	
DATE:	SIGN:	

## PROBLEM DESCRIPTION:

## SOLUTION PROPOSAL:

## EVALUATION:

## APPROVERS

Notitie: Indien nodig, kunt u door middel van het bovenstaande formulier of per e-mail uw problemen naar ons bedrijf sturen.